

DALMINEUS

**DALMINEUS**  
LOGISTIC SOLUTIONS

# Scaffalatura drive-in

## Drive-in racking



## Scaffalatura drive-in Bi-Bloc

*Drive-in shelving with loadable aisles*  
*Drive-in Regalsystem mit beladbaren Gängen*  
*Rayonnage drive-in à couloirs chargeables*  
*Estantería drive-in a pasillos de carga*

Scaffalatura ad accumulazione particolarmente indicata quando è necessario stoccare grandi quantità di prodotti in relazione a poche referenze.

Le unità di carico pallettizzate sono immagazzinate, secondo la logica "First In, Last Out" e "Last In, First Out", in corridoi sviluppati in profondità, accessibili con i carrelli elevatori per effettuare le operazioni di movimentazione. È possibile così sfruttare lo spazio in modo intensivo, eliminando i corridoi di servizio dei sistemi tradizionali.

La scaffalatura drive-in è realizzata con il sistema ad incastro Bi-Bloc, completa dell'esclusivo profilo porta-pallet in acciaio zincato.

*Accumulation shelving recommended for great amounts of goods with few ID references. According to the 'First In, Last Out' and 'Last-In, First-Out' principle, the palletized load unit are stored into deep tunnels accessible by fork lifts for handling operations. This allows exploiting as much room as possible and eliminating the aisles traditionally required for service purposes.*

*The drive-in shelving is made with the Bi-Bloc slot-in system, and is completed by the exclusive pallet rack profile of zinc-coated steel.*

*Ein Speicher-Regalsystem, welches sich besonders für die Lagerung großer Produktmengen eignet, die nur einen geringen Aufwand an Bezeichnung zur Identifizierung benötigen. Die palettierten Ladungseinheiten werden nach der Regel "First In, Last Out" und "Last In, First Out" gelagert. Die in die Tiefe entwickelten Ladegänge sind mit den Gabelstaplern für alle Bewegungs- und Transportvorgänge zu erreichen. Der zur Verfügung stehende Platz kann auf diese Weise intensiv genutzt werden, die Servicegänge herkömmlicher Systeme werden eliminiert. Das Drive-In System wird mit dem Klemm-System Bi-Bloc erstellt, welches bereits mit dem exklusiven Paletten-Trageprofil in verzinktem Stahl ausgestattet ist.*

*Rayonnage ad accumulazione fortemente recomman dé pour stocker des quantités importantes sous peux de références. Les unités de charge sur palettes sont stockées selon le principe de "First In, Last Out" et "Last In, First Out" (soit une circulation des marchandises ou "le premier qui rentre est le dernier à sortir"). Le stockage se fait sur des couloirs développés en profondeur, accessibles par chariot élévateur pour la manipulation des palettes.*

*Il est donc possible d'exploiter la place disponible au maximum, en éliminant les couloirs de service stockage traditionnel.*

*Le stockage drive in est constitué par un système a échelles Bi-Bloc complet avec son exclusif profil porte-palettes en acier galvanisé.*



*Estanterías de acumulación particularmente indicadas cuando sea necesario almacenar grandes cantidades de productos con relación a pocas referencias.*

*Las unidades de carga paletizadas están almacenadas, según la lógica "First In, Last Out" y "Last In, First Out", en pasillos construidos en profundidad, accesibles con los elevadores para efectuar las operaciones de movimiento de esta manera es posible aprovechar el espacio al máximo, eliminando los pasillos de servicio de los sistemas tradicionales. La estantería drive-in está realizada con el sistema de encaje Bi-Bloc, completa con el exclusivo perfil porta paletas de acero galvanizado.*

### PORTATE Capacities

- Il drive-in è dimensionato per pallet standard fino a 1500 kg anche in zona sismica.
- The drive-in is dimensioned for pallets up to 1500 kg, also in seismic belt areas.
- Das drive-in System hat eine Abmessung für Paletten bis 1500 kg auch in Erdbebengebieten.
- Le drive-in a des dimensions pour des palettes ayant un poids jusque 1500 kg, aussi dans une région sismique.
- El drive-in está dimensionado para paletas hasta 1500 kg, también en zona sísmica.



## MATERIALE Material

- Spalle: acciaio altoresistenziale zincato Sendzimir S350 GD UNI EN 10326
- Mensole: acciaio altoresistenziale zincato Sendzimir S 280 GD UNI EN 10326
- Profili portapallet: acciaio altoresistenziale zincato Sendzimir S280 GD UNI EN 10326

- *Abutments: high-resistance hot-dip Sendzimir galvanized steel S350 GD UNI EN 10326*
- *Planks: high-resistance hot-dip Sendzimir galvanized steel S 280 GD UNI EN 10326*
- *Pallet rack profiles: high-resistance hot-dip galvanized steel S280 GD UNI EN 10326*

- *Schultern: Hochfestigkeits-, Sendzimir verzinktes Stahl S350 GD UNI EN 10326*
- *Regalböden: Hochfestigkeits-, Sendzimir verzinktes Stahl S 280 GD UNI EN 10326*
- *Paletten-Trageprofile: Hochfestigkeits-, Sendzimir verzinktes Stahl S 280-GD*

- *Culées en acier haute résistance galvanisé Sendzimir S350 GD UNI EN 10326*
- *Planches en acier haute résistance galvanisé Sendzimir S 280 GD UNI EN 10326*
- *Profils porte-palettes en acier haute résistance galvanisé Sendzimir S280 GD UNI EN 10326*

- *Estribos de acero alta resistencia galvanizado S350 GD UNI EN 10326*
- *Ménsulas: acero alta resistencia galvanizado Sendzimir S 280 GD UNI EN 10326*
- *Perfiles portapaletas: acero alta resistencia galvanizado Sendzimir S280 GD UNI EN 10326*

## CARATTERISTICHE Characteristics

- Larghezza del tunnel: 1350 mm e 1400 mm standard.
- Altezza tunnel: fino a 12 m.
- Sicurezza:
  - Sistema antisfilamento a spina/bullone che impedisce il disinnesto della mensola;
  - Protezioni dei montanti con profili speciali di acciaio verniciato.
- Accessori:
  - Guide a terra con relativi imbocchi;
  - Fermi pallet.

- Tunnel length: 1350 mm and 1400 mm standard.
- Tunnel height: up to 12 m.

- Safety:
  - Anti-unlocking pin/bolt system to prevent bracket detachment;
  - Upright protection with painted steel special profiles.

- Accessories:
  - Ground slides with respective mouths;
  - Pallet stopper.

- Tunnelbreite: Standard 1350 mm und 1400 mm.

- Tunnelhöhe: bis zu 12 m.

- Sicherheit:
  - Anti-Herausrutsch-System durch Stifte/Bolzen, welches das Auskuppeln des Regalbodens verhindert;
  - Schutz der Pfosten durch spezielle lackierte Edelstahlprofile.

- Zubehör:
  - Bodenführungen mit entsprechenden Eingriffen;
  - Paletten-Feststeller.

- Largeur du tunnel 1350 et 1400 mm standard.

- Hauteur du tunnel: jusqu'à 12 m.

- Sécurité:
  - Système anti-coulissement à manchon/boulon qui empêche le décrochement accidentel des étages;
  - Protection des montants par des profils spéciaux en acier peint;

- Accessoires:
  - Glissières au sol avec bouches;
  - Arrêts palette.

- Anchura del tunel: 1350 mm e 1400 mm estandar.

- Altura tunel hasta 12 m.

- Seguridad:
  - Sistema antideslizamiento atornillado, que impide la desconexión del carril de posicionamiento;
  - Protecciones de los bastidores con perfiles especiales de acero pintado.

- Accesorios:
  - Guías de tierra con relativas entradas;
  - Tope paleta.

## Norme di produzione

Manufacturing standards - Produktionsnormen - Normes de production - Normas de producción

DalmineLS ha in corso l'adeguamento della gamma produttiva alle seguenti Norme Europee:

- UNI EN 15620:2009 del 11/06/09
- UNI EN 15629:2009 del 19/03/09
- UNI EN 15635:2009 del 19/03/09

## Componenti Bi-Bloc drive-in

*Bi-Bloc drive-in components*

*Bestandteile des Bi-Bloc drive-in*

*Composants d'un système Bi-Bloc drive-in*

*Componentes Bi-Bloc drive-in*

Il gruppo mensola-profilo porta pallet di tipo tradizionale ha caratterizzato la produzione DalmineLS per molti anni. Tuttavia oggi è disponibile anche una soluzione ingegneristica più avanzata in sostituzione.

*The bracket-pallet rack profile has been a peculiar manufacture for many years among the products of DalmineLS. Today though, a new, advanced solution that replace this traditional group is available.*

*Die Produktion der DalmineLS ist lange Jahre durch die Gruppe der herkömmlichen Regalböden/Paletten-Trageprofile charakterisiert worden. Heutzutage ist jedoch eine technisch fortschrittlichere Lösung vorhanden.*

*Le composant planche-profil traditionnel était la base de la production DalmineLS pendant des années. Toutefois, aujourd'hui, un nouveau système plus avancé du point de vue technologique est disponible.*

*Perfil de apoyo paleta que caracterizado la producción DalmineLS durante muchos años. Aún así se está estudiando una solución de ingeniería más avanzada como sustitución.*



## MENSOLA

Bracket - Einlegeboden - Planche - Ménsula

- Realizzata in tubo, saldata ad un attacco con ganci per l'incastro al montante.
- *Made of tubing and welded to a hooked joint for the connection with the upright*
- *Aus Rohr bestehend, an einem für die Verbindung mit dem Pfeiler Hakengelenk zugeschweißt*
- *Réalisée en tube, et présentant un accroche avec agrafes permettant de la fixer au montant.*
- *Cartela con doble encaje para la conexión al puntal.*

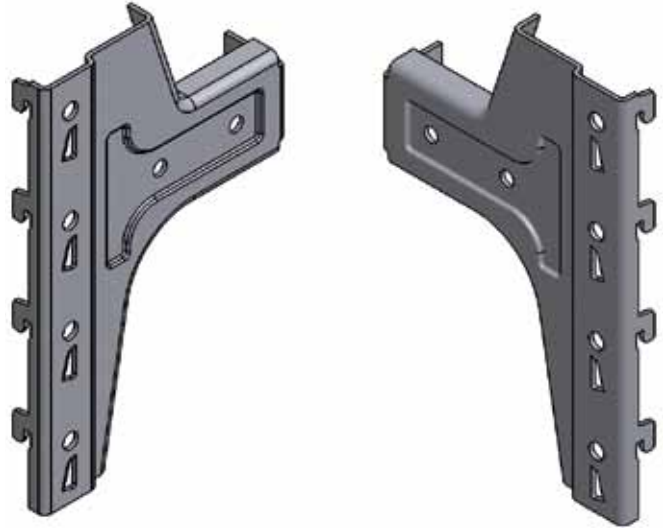

### PORTATA MENSOLA - Bracket load capacity

Lunghezza mensola (mm) Bracket length (mm)	Portata mensola (daN) Bracket load capacity (daN)
135	835
160	780

## PROFILO PORTA-PALLET

Pallet rack profile - Paletten-Trageprofil - Profil porte-palettes - Perfil porta-paleta

- Profilo sagomato di tipo aperto. La sua geometria consente, oltre al sostegno, la centratura e la guida dei pallet.
- *Cold-formed, open profile that allows, bearing, centering and sliding the pallet.*
- *Kaltgeformtes, offenes Profil. Seine Geometrie erlaubt die Zentrierung und Führung sowie den Halt der Paletten.*
- *Profil ouvert dont le dessin permet soit une action portante, le centrage e le coulissement des palettes.*
- *Perfil diseñado para guiar, centrar y almacenar las unidades de carga con las mismas dimensiones.*

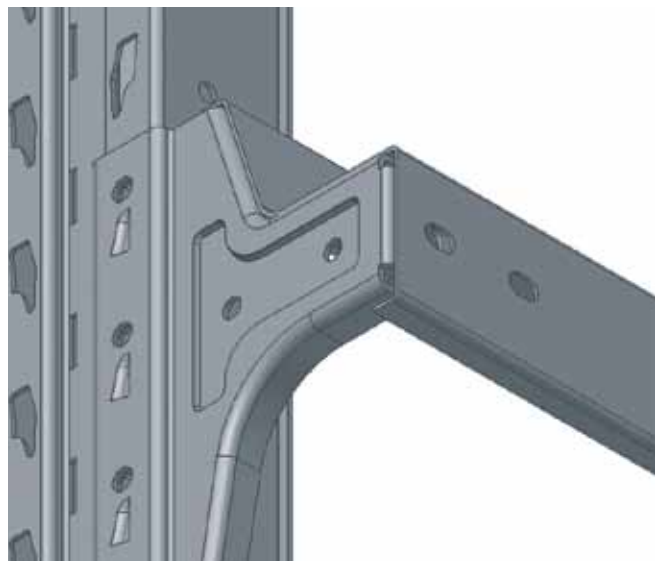

## PROFILO PORTA PALLET + GUIDA

Pallet rack profile + Slide

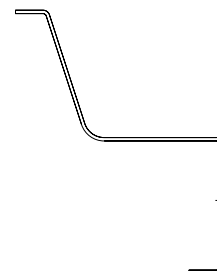
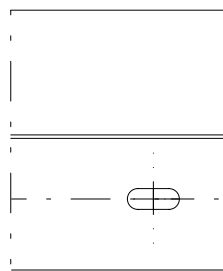
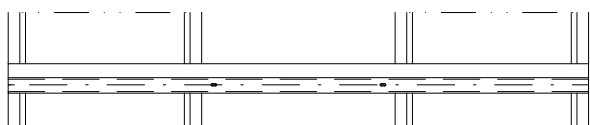

### PORTATE - Load capacity

Spessore Thickness	1,5	2,0	2,5	3,0
Peso max pallet Max pallet weight	1100	1500	1800	2200
Luce (mm) Clearance (mm)	Portata per coppia (per ml) Load capacity each pair (per ml)	Portata max pallet (prof.=800) Pallet's max. capacity (depth = 800)	Portata max pallet (prof.=1000) Pallet's max. capacity (depth = 1000)	Portata max pallet (prof.=1200) Pallet's max. capacity (depth = 1200)
800	2900	1500	1500	1500
900	2290	1500	1500	1500
1000	1850	1480	1500	1500
1100	1530	1220	1500	1500
1200	1290	1030	1290	1500
1300	1090	870	1090	1310
1400	940	750	940	1130
1500	820	660	820	990
1600	720	580	720	870
1700	640	510	640	770



**Basetta 2F**  
2F base plate

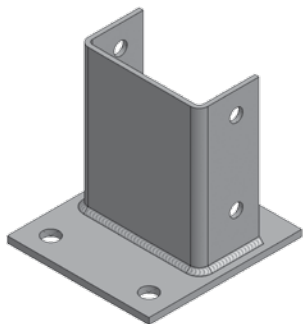

**Basetta con invito**  
Base plate with slide

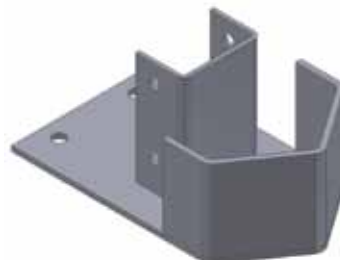

**Basetta 4F**  
4F base plate

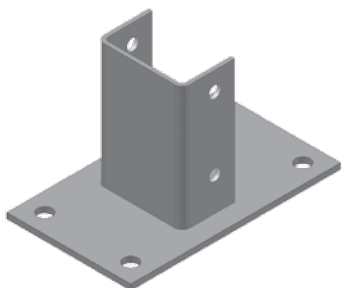

**Basetta con invito e protezione**  
Base plate with slide and protection

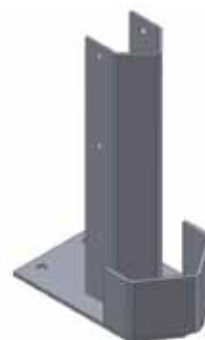

**Basetta con protezione**  
Base plate with protection

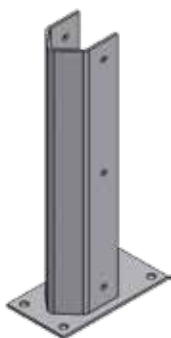

**Montante**  
Upright



**Guida a terra**  
Ground slide



**Traversi e diagonali spalle**  
Upright frame composition

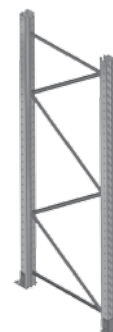



**Collegamento spalle**  
*Upright frames connection*

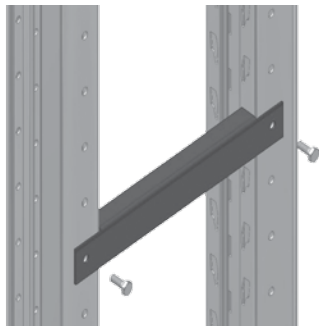

**Attacco controvento spalle**  
*Upright frame bracing connection*

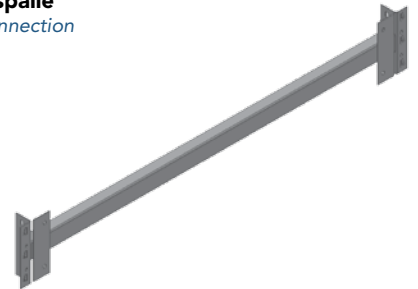

**Ferma pallet posteriore**  
*Rear pallet stopper*

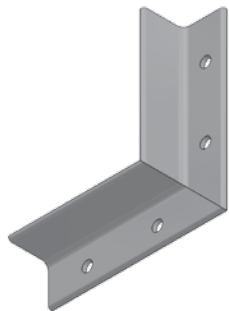

**Attacco controvento orizzontale**  
*Horizontal bracing connection*

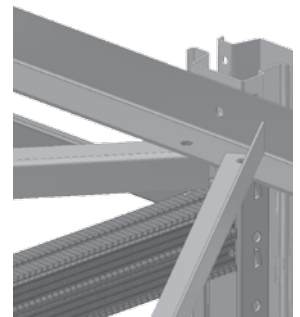

**Ferma pallet intermedio**  
*Intermediate pallet stopper*

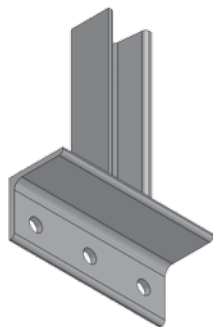

**Giunto porta pallet**  
*Pallet rack joint*

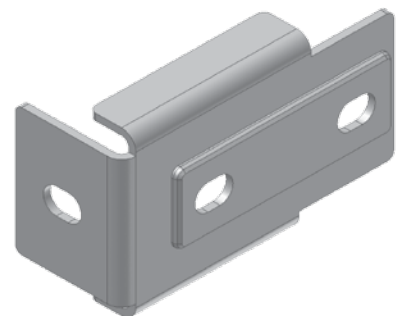

**Diagonali in controvento**  
*Bracing element*



**Invito profilo porta pallet**  
*Pallet rack profile slide*

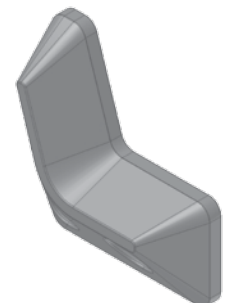

# DALMINELS

LOGISTIC SOLUTIONS

**Headquarters**

viale del Commercio, 36  
29122 Piacenza - Italy  
phone +39 . 0523 17 37 911  
fax +39 . 0523 17 37 912  
news@dalminels.com  
www.dalminels.com

**Potenza plant**

via della Fisica, 19  
85100 Potenza - Italy

**Graffignana plant**

via S. Colombano, 63  
26813 Graffignana, Lodi - Italy